

DSCP20



Programmable 2-Wire Temperature Transmitter, DIN Mount

Description

Each DSCP20 2-wire transmitter is designed for measuring temperature using thermocouples or RTDs. The input type, measurement range, and other features are software configurable. A PC, the DSCX-887 and DSCX-416 interface cables, and the DSCX-895 configuration software are required to configure the transmitter. Communication is serial RS-232C.

The DSCP20 can interface to 12 industry standard thermocouple types: J, K, T, E, R, S, B, N, L, U, C, and D. Cold junction compensation is selectable as either internal or external. Three RTD types, Pt 100, Ni 100, and Cu 50* can be interfaced in a two, three or four wire connection. All inputs are linearized using up to 23 points of interpolation, and total errors are less than $\pm 0.2\%$.

Other configurable features include: zero point and input range adjustment, output response for open or short-circuit sensor or cable failure, normal or inverted output, ripple suppression for 50Hz or 60Hz, and output time response. The DSCX-895 configuration software allows query, print-out and saving of configuration settings, display of input measurement value, and display of interpolation table points.

*Call factory for Cu RTD information.

► Features

- Low-Cost Non-Isolated 4-20mA Transmitter
- No Power Supply Required, Powered from Output Loop Current
- Interfaces to All Standard Thermocouples and RTDs
- Software Configurable Input Type and Range
- Open and Short-Circuit Input Detection
- Configurable with or without Output Loop Power Connected
- Mounts on Standard DIN Rail
- -25°C to +80°C Operating Temperature
- CE Compliant

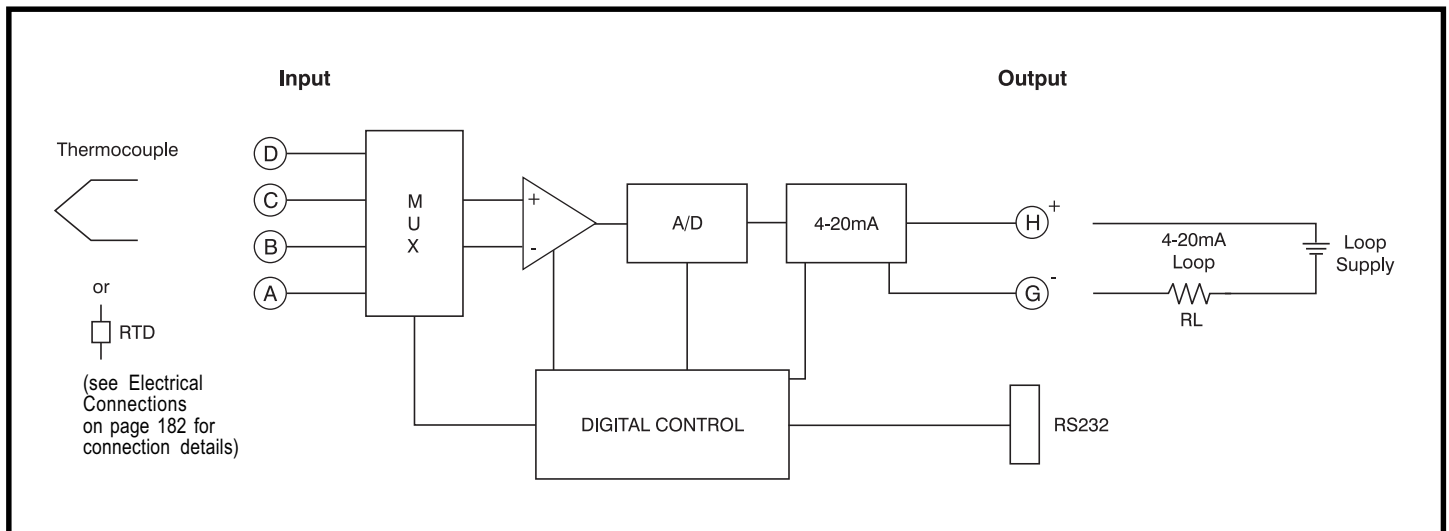

Figure 1: DSCP20 Block Diagram

Thermocouple Type and Material

Type	Material
B	Pt30Rh-Pt6Rh
E	NiCr-CuNi
J	Fe-CuNi
K	NiCr-Ni
L	Fe-CuNi
N	NiCrSi-NiSi
R	Pt13Rh-Pt
S	Pt10Rh-Pt
T	Cu-CuNi
U	Cu-CuNi
C	W5 Re/W26 Re
D	W3 Re/W25 Re

Specifications Typical at T_a = +25°C, 24V loop supply voltage, R_L = 250Ω; PT100, 3 wire, 0-600°C

Module	DSCP20
Input Range, Thermocouple Thermocouple Types: B, E, J, K, N, R, S, T, L, U, C, D Cold Junction Compensation Internal External Input Resistance	Reference Table 1 Incorporated Pt 100 0 to 60°C, Configurable >10MΩ
Input Range, RTD RTD Types: Pt 100, Ni 100 RTD Excitation Current Input Resistance Lead Resistance	Reference Table 1 ≤0.20mA >10MΩ ≤30Ω per Lead
Output Range Output Noise Loop Supply Voltage Reverse Supply Protection Load Resistance Output Response for Input Failure Output Time Response	4 to 20mA or Inverse 20 to 4mA <1% p-p 12 to 30 VDC Continuous See Note 1 Configurable to hold value of output immediately prior to input failure, or value between 4 and 21.6mA Configurable, see Table 2
Accuracy ⁽²⁾	±0.1% Span Typ., ±0.2% Span max.†
Linearity	±0.03% Span Typ., ±0.1% Span max.
Stability	≤±(0.015%+0.015°C)/°C
Environmental Operating Temp. Range Storage Temp. Range Relative Humidity Emissions Immunity	-25°C to +80°C -40°C to +80°C 0 to 75% Noncondensing EN50081-2 (Radiated, Conducted) EN50082-2 (ESD, RF, EFT)
Mechanical Dimensions (h)(w)(d)	2.44" x 0.67" x 2.56" (62mm x 17mm x 65mm)
Housing Material	Polyamide, Flammability Class V2 According to UL 94
Mounting	DIN EN 50022-35x7.5 or EN 50035-G32

NOTES:
(1): Load Resistance: $R_L(\text{max}) = \frac{\text{Loop Supply (V)} - 12V}{I_{\text{OUTPUT}}(\text{max})}$

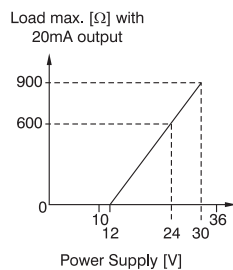

- (2) Includes hysteresis, conformity and repeatability at reference conditions. Does not include CJC error.
- (3) Shipped as PT 100 for 3-wire connection, 0 to 600°C range, 4 to 20mA output, open circuit detect = 21.6mA output.
- (4) Submit configuration form shown on page 180, and factory will assign part number prior to order entry.
- (5) Many different ranges may be programmed as long as the min/max limits are observed. For minimum range examples, a K type thermocouple could be programmed for +30°C to +78.5°C, or +100°C to +149°C, or +900°C to 995°C, and so on.

Ordering Information

Model	Input Range/Description	Output Range
DSCP20 (Basic Configuration) ⁽³⁾	Configurable RTD or Thermocouple, User Programmed	4 to 20mA, or Inverted
DSCP20-xxxx (Contact Factory) ⁽⁴⁾	Configurable RTD or Thermocouple, Factory Programmed	4 to 20mA, or Inverted

Accessories

Model	Description
DSCX-887	PC Interface Cable
DSCX-416	Module Interface Cable
DSCX-895	Configuration Software

Table 1

Measured Variables	Measuring Ranges		
	Limits	Min. Span	Max. Span
RTD: 2, 3, or 4-wire Pt 100, Standard IEC 60 751 Ni 100, Standard DIN 43 760	-200 to +850°C -60 to +250°C	50°C 50°C	850°C 250°C
Thermocouple Type B, E, J, K, N, R, S, T; Standard IEC 60 584-1 Type L and U; Standard DIN 43 710 Type C: W5 Re/W26 Re, Type D: W3 Re/W25 Re; Standard ASTM E 988-90	According to type	2mV ⁽⁵⁾	80mV ⁽⁵⁾

Table 2: Output Response Times

Measuring Mode	Open Sensor Circuit	Short-Circuit	Possible Response Times [s]							
			1.5	2.5	3.5	6.5	11	20.5	40	
TC int. comp.	active	–	1.5	2.5	3.5	6.5	11	20.5	40	
TC int. comp.	off	–	1.5	2.5	3.5	6.5	13.5	24.5	49.5	
TC ext. comp.	active	–	1.5	2.5	3.5	6.5	11	20.5	40	
TC ext. comp.	off	–	1.5	2.5	4	6.5	13.5	24.5	48.5	
RTD 2L	active	–	2	2.5	3	5	9.5	17.5	33.5	
RTD 3L, 4L	active	active	2	2.5	4	6.5	11.5	21	40.5	
RTD 2L, 3L, 4L	off	off	1.5	2.5	3.5	7.5	14	26.5	50.5	

†Additional Errors

Low Measuring Range Resistance Thermometer (<200°C Span) Thermocouples (<500°C Span)		±0.015% Span Typ., ±0.05% Span max ±0.015% Span Typ., ±0.05% Span max
High Initial Value	Factor: Error:	±0.0002 Typ., ±0.0005 max (Factor)*(Initial Value/Span)*100 [%]
Influence of Lead Resistance		±0.01% per Ω
Internal Cold Junction Compensation		±(0.5°C/Span)*(100) [%]

DSCP

Table 3: Specification and Ordering Information for Factory Configuration

Part Number: DSCP20-xxxx. xxxx is factory assigned part number	xxxx =
Features, Selection	
1. Temperature units	
1) Temperatures in °C	<input type="checkbox"/>
2) Temperatures in °F	<input type="checkbox"/>
3) Temperatures in K	<input type="checkbox"/>
2. Measuring mode, input connection	
Thermocouple	
1) Internal cold junction compensation, with built-in or external PT100	<input type="checkbox"/>
2) External cold junction compensation, by fixed junction temperature (see NOTE A)	Specify: _____ °
Resistance thermometer	
3) Two-wire connection, R_L (see NOTE B)	Specify: _____ Ω
4) Three-wire connection, $R_L \leq 30\Omega$ /wire	<input type="checkbox"/>
5) Four-wire connection, $R_L \leq 30\Omega$ /wire	<input type="checkbox"/>
NOTE A: Specify external cold junction temperature t_c (in °C, °F or K, acc. to selection in Feature 1), any value between 0 and 60°C or equivalent	
NOTE B: Specify total lead resistance R_L [Ω], any value between 0 and 60Ω	
3. Sensor type/measuring range	
Sensor type/beginning...end value of measuring range*	Specify Range:
1) RTD Pt 100	Specify: _____ Ω (See Note) _____ ° to _____ °
2) RTD Ni 100	Specify: _____ Ω (See Note) _____ ° to _____ °
B) TC Type B _____ ° to _____ °	N) TC Type N _____ ° to _____ °
E) TC Type E _____ ° to _____ °	R) TC Type R _____ ° to _____ °
J) TC Type J _____ ° to _____ °	S) TC Type S _____ ° to _____ °
K) TC Type K _____ ° to _____ °	T) TC Type T _____ ° to _____ °
L) TC Type L _____ ° to _____ °	U) TC Type U _____ ° to _____ °
C) TC W5-W26RE _____ ° to _____ °	D) TC W3-W25RE _____ ° to _____ °
*Specify measuring range in [°C], [°F], or [K]; refer to table 4 for the max range operating limits for each type of sensor, and table 1 for min/max span limits.	
NOTE: Specify resistance in Ω at 0°C, any value between 50 and 1000Ω	
4. Output characteristic	
0) Standard 4-20mA	<input type="checkbox"/>
1) Inverted 20-4mA	<input type="checkbox"/>
5. Open and short-circuit sensor detection	
Output response for an open or short-circuit* sensor	
0) Output 21.6mA	<input type="checkbox"/>
1) Output (see NOTE)	Specify: _____ mA
2) Hold output at last value	<input type="checkbox"/>
A) No signal	<input type="checkbox"/>
NOTE: Any value between 4 and <21.6mA *The short-circuit signal is only active for RTD measuring $\geq 100\Omega$ at 0°C and three or four-wire connection	
6. Output time response	
0) Standard response time approx. 2 seconds	<input type="checkbox"/>
9) Response time (see NOTE)	Specify: _____ s
NOTE: For admissible values see Table 2	
7. Mains ripple suppression	
0) Frequency 50 Hz	<input type="checkbox"/>
1) Frequency 60 Hz	<input type="checkbox"/>

Table 4: Temperature Measuring Ranges

Measuring range examples [°C]	Resistance thermometers		Thermocouples												
	Pt100	Ni100	B	E	J	K	L	N	R	S	T	U	C ⁽¹⁾	D ⁽²⁾	
0...40	X			X	X		X								
0...50	X	X		X	X	X	X				X	X			
0...60	X	X		X	X	X	X				X	X			
0...80	X	X		X	X	X	X	X			X	X			
0...100	X	X		X	X	X	X	X			X	X			
0...120	X	X		X	X	X	X	X			X	X			
0...150	X	X		X	X	X	X	X			X	X	X		
0...200	X	X		X	X	X	X	X			X	X	X	X	
0...250	X	X		X	X	X	X	X			X	X	X	X	
0...300	X			X	X	X	X	X	X	X	X	X	X	X	
0...400	X			X	X	X	X	X	X	X	X	X	X	X	
0...500	X			X	X	X	X	X	X	X		X	X	X	
0...600	X			X	X	X	X	X	X	X		X	X	X	
0...800	X		X	X	X	X	X	X	X	X			X	X	
0...900			X	X	X	X	X	X	X	X			X	X	
0...1000			X	X	X	X		X	X	X			X	X	
0...1200			X		X	X		X	X	X			X	X	
0...1500			X						X	X			X	X	
0...1600			X						X	X			X	X	
0... 1800			X										X	X	
0... 2000													X	X	
50...150	X	X		X	X	X	X	X			X	X			
100...300	X			X	X	X	X	X			X	X	X	X	
200...500	X			X	X	X	X	X	X	X		X	X	X	
300...600	X			X	X	X	X	X	X	X		X	X	X	
600...900			X	X	X	X	X	X	X	X			X	X	
600...1000			X	X	X	X		X	X	X			X	X	
900...1200			X		X	X		X	X	X			X	X	
600...1600			X						X	X			X	X	
600...1800			X										X	X	
-10...40	X	X		X	X	X	X					X			
-30...60	X	X		X	X	X	X	X			X	X			
Measuring range limits [°C]	-200 to 850	-60 to 250	0 to 1820	-270 to 1000	-210 to 1200	-270 to 1372	-200 to 900	-270 to 1300	-50 to 1769	-50 to 1769	-270 to 400	-200 to 600	0 to 2315	0 to 2315	
	NOTE A		NOTE B												
<p>NOTE A: Minimum span is 15Ω when the end value⁽³⁾ is less than or equal to 400Ω. Minimum span is 150Ω when the end value⁽³⁾ is greater than 400Ω and not exceeding 4000Ω. The ratio of the min value to the span must be less than or equal to 10.</p> <p>NOTE B: Range of span is 2mV minimum to 80mV maximum. The ratio of the min value to the span must be less than or equal to 10.</p> <p>NOTE (1): W5 Re W26 Re (ASTM E 988-90) NOTE (2): W3 Re W25 Re (ASTM E 988-90) NOTE (3): For two-wire connections, the end value is made up of the measured end value (Ω) plus the total resistance of the leads.</p>															

DSCP

Electrical Connections

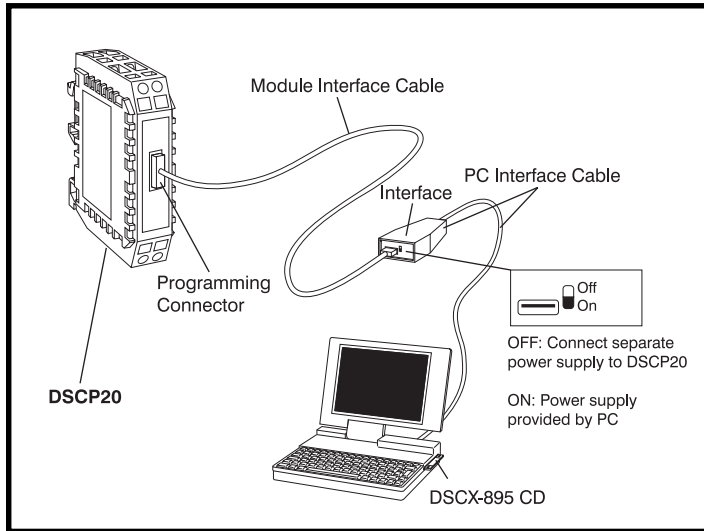
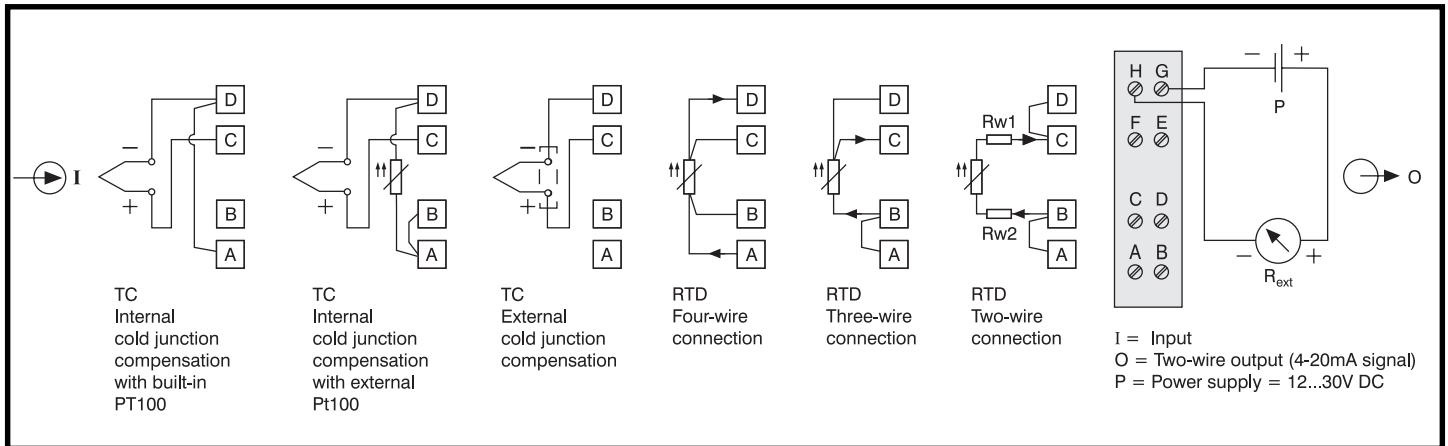
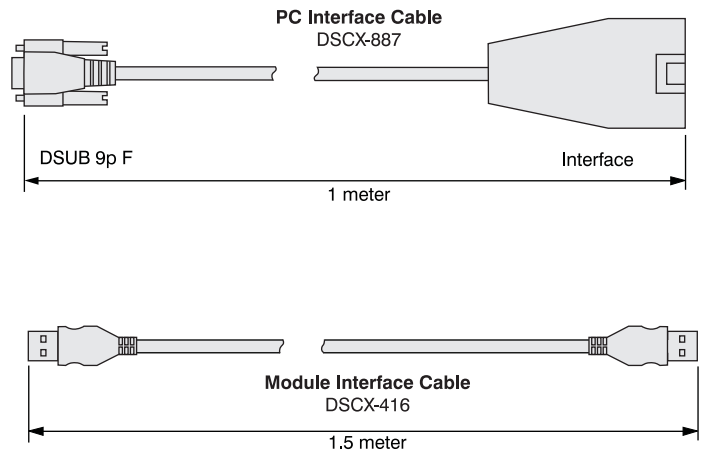

Table 5: Accessories and Spare Parts



Example of the set-up for programming a DSCP20 without the power supply. For this case the switch on the interface must be set to "ON".

Dimensions

Dimensions: inches (millimeters)

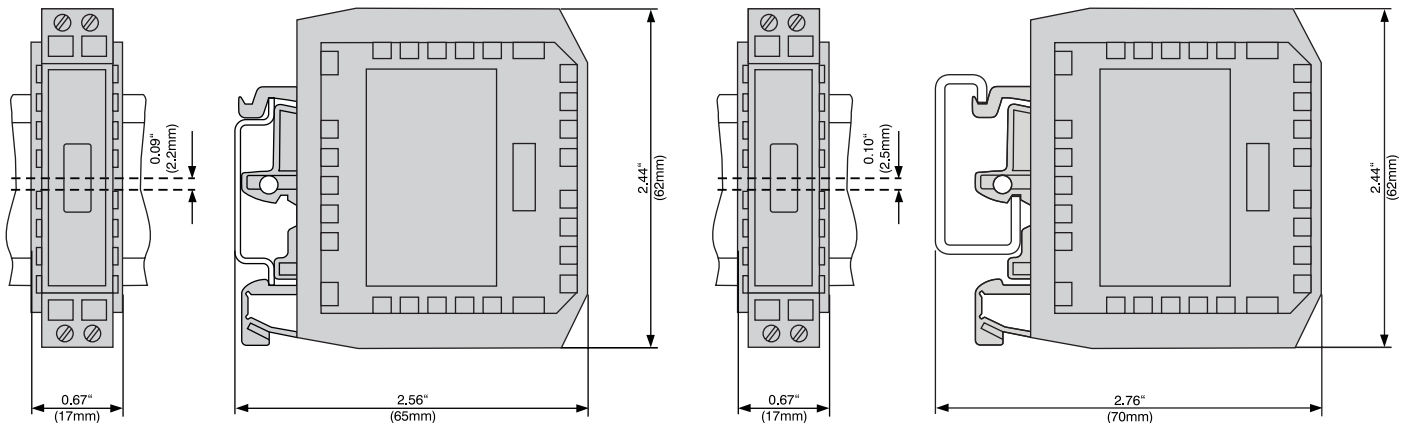

DSCP20 Clipped onto a Top-Hat Rail EN 50-022-35 x 7.5

DSCP20 Clipped onto a Rail "G" EN 50-035-G32