

DSCP80

Programmable Temperature Transmitter, DIN Mount



Description

Each isolated DSCP80 transmitter is designed for measuring temperature using thermocouples or RTDs. The input type, measurement range, and other features are software configurable. A PC, the DSCX-887 and DSCX-416 interface cables, and the DSCX-895 configuration software are required to configure the transmitter. Communication is serial RS-232C.

The DSCP80 can interface to 12 industry standard thermocouple types: J, K, T, E, R, S, B, N, L, U, C, and D. Cold junction compensation is selectable as either internal or external. Three RTD types, Pt 100, Cu 50*, and Ni 100, can be interfaced in a two, three or four wire connection. All inputs are linearized using up to 23 points of interpolation, and total errors are less than $\pm 0.2\%$.

Other configurable features include: zero point and input range adjustment, output response for open or short-circuit sensor or cable failure, normal or inverted output, ripple suppression for 50Hz or 60Hz, and output time response. The DSCX-895 configuration software allows query, print-out and saving of configuration settings, display of input measurement value, and display of interpolation table points.

*Call factory for Cu RTD information.

► Features

- Interfaces to All Standard Thermocouples and RTDs
- Software Configurable Input Type and Range
- 2300Vrms Transformer Isolation
- Supply Voltage of 24 to 60VDC/AC or 85 to 230VDC/AC
- Open and Short-Circuit Input Detection
- Configurable with or without Power Connected
- Mounts on Standard DIN Rail
- -25°C to +55°C Operating Temperature
- CE Compliant

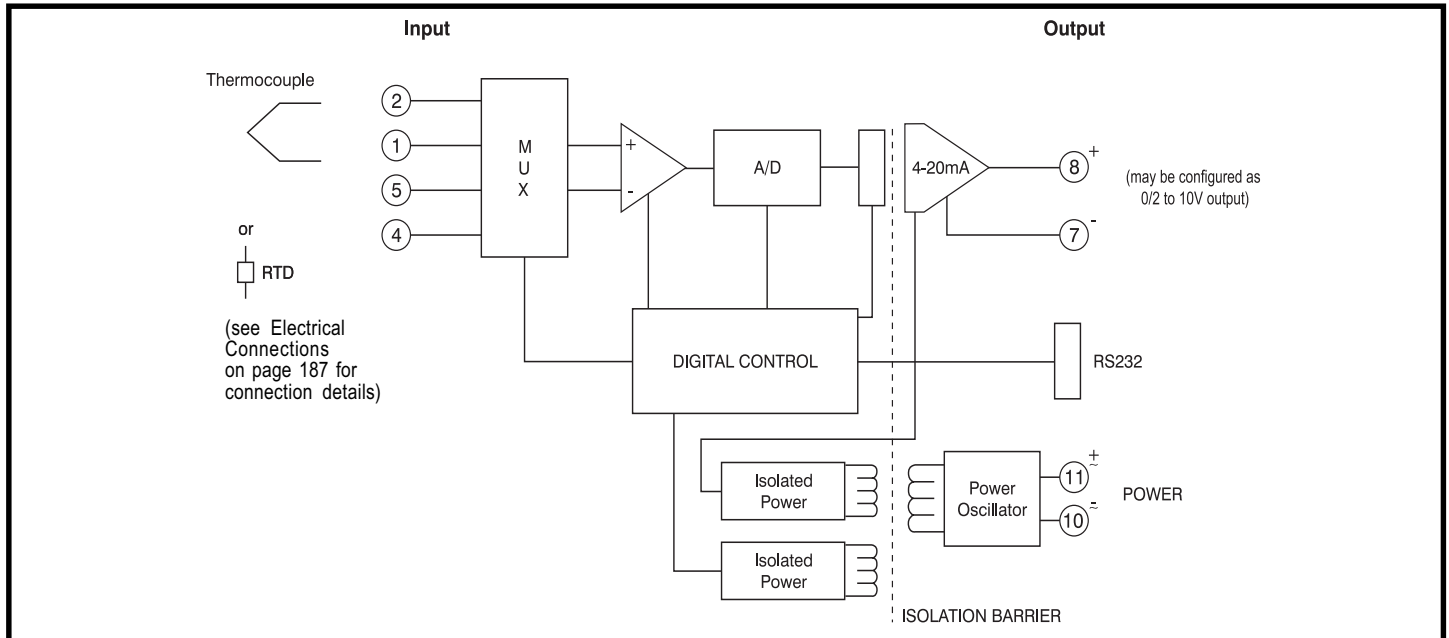

Figure 1: DSCP80 Block Diagram

Thermocouple Type and Material

Type	Material
B	Pt30Rh-Pt6Rh
E	NiCr-CuNi
J	Fe-CuNi
K	NiCr-Ni
L	Fe-CuNi
N	NiCrSi-NiSi
R	Pt13Rh-Pt
S	Pt10Rh-Pt
T	Cu-CuNi
U	Cu-CuNi
C	W5 Re/W26 Re
D	W3 Re/W25 Re

Specifications Typical at T_A=+25°C and 24VDC or 230VAC ±10% supply voltage, R_L=300Ω (I_{OUT}), R_L=4kΩ (V_{OUT}), PT100, 3-wire, 0-600°C

Module	DSCP80
Input Range, Thermocouple Thermocouple Types: B, E, J, K, N, R, S, T, L, U, C, D Cold Junction Compensation Internal External Input Resistance	Reference Table 1 Incorporated Pt 100 0 to 60°C, configurable >10MΩ
Input Range, RTD RTD Types: Pt 100, Ni 100 RTD Excitation Current Lead Resistance	Reference Table 1 ≤0.20mA ≤30Ω per lead
Output Range Load Resistance CMV, Input to Output CMV, Power Supply to In/Out Output Noise Open Circuit V, Short Circuit I Output Response for Input Failure Output Time Response	0/4 to 20mA, 20 to 0/4mA, 0/2 to 10V, 10 to 0/2V ≤600Ω current output mode, ≥2kΩ voltage output mode 2300Vrms, 1 min. 3700Vrms, 1 min. <1.5% p-p <20V current output mode, ≤40mA voltage output mode Configurable to hold value of output immediately prior to input failure, or value between 0 and 22mA, or 0 and 11V Configurable, see Table 2
Accuracy ⁽¹⁾	±0.1% Span Typ., ±0.2% Span max. ¹
Linearity	±0.03% Span Typ., ±0.1% Span max.
Stability	≤±(0.015%+0.015°C)/°C
Power Supply Voltage Tolerance Power Consumption	24 to 60VDC/AC, or 85 to 230VDC/AC DC -15% to +33%, AC ±15% DC ≤1.0W, AC ≤2.1VA
Environmental Operating Temp. Range Storage Temp. Range Relative Humidity Emissions Immunity	-25°C to +55°C -40°C to +70°C 0 to 75% Noncondensing EN50081-2 (Radiated, Conducted) EN50082-2 (ESD, RF, EFT)
Mechanical Dimensions (h)(w)(d)	2.72" x 0.69" x 4.49" (69.2mm x 17.5mm x 114mm)
Housing Material	Lexan 940, Flammability Class V-0 acc. to UL 94
Mounting	DIN EN 50022-35x7.5 or -35x15

†Additional Errors

Low Measuring Range Resistance Thermometer (<200°C Span) Thermocouples (<500°C Span)	±0.015% Span Typ., ±0.05% Span max ±0.015% Span Typ., ±0.05% Span max
High Initial Value Factor: Error:	±0.0002 Typ., ±0.0005 max (Factor)*(Initial Value/Span)*100 [%]
Influence of Lead Resistance	±0.01% per Ω
Internal Cold Junction Compensation	±(0.5°C/Span)*(100) [%]

NOTES:

- (1) Includes hysteresis, conformity and repeatability at reference conditions. Does not include CJC error.
- (2) Shipped as PT 100 for 3-wire connection, 0 to 600°C range, 4 to 20mA output, open circuit detect = 21.6mA output.
- (3) Shipped as PT 100 for 3-wire connection, 0 to 600°C range, 0 to 10V output, open circuit detect = 11.0V output.

Ordering Information

Model	Input Range/Description	Output Range
DSCP80-01 (Basic Configuration) ⁽²⁾	User Configurable RTD or Thermocouple, 24 to 60VDC/AC Power	0/4 to 20mA, or Inverted
DSCP80-02 (Basic Configuration) ⁽²⁾	User Configurable RTD or Thermocouple, 85 to 230VDC/AC Power	0/4 to 20mA, or Inverted
DSCP80-03 (Basic Configuration) ⁽³⁾	User Configurable RTD or Thermocouple, 24 to 60VDC/AC Power	0/2 to 10V, or Inverted
DSCP80-04 (Basic Configuration) ⁽³⁾	User Configurable RTD or Thermocouple, 85 to 230VDC/AC Power	0/2 to 10V, or Inverted
DSCP80-01/-03-xxxx (Contact Factory) ⁽⁴⁾	Factory Configured RTD or Thermocouple, 24 to 60VDC/AC Power	0/4 to 20mA, 0/2 to 10V, or Inverted
DSCP80-02/-04-xxxx (Contact Factory) ⁽⁴⁾	Factory Configured RTD or Thermocouple, 85 to 230VDC/AC Power	0/4 to 20mA, 0/2 to 10V, or Inverted

Accessories

Model	Description
DSCX-887	PC Interface Cable
DSCX-416	Module Interface Cable
DSCX-895	Configuration Software

Table 1

Measured Variables	Measuring Ranges		
	Limits	Min. Span	Max. Span
RTD: 2, 3, or 4-wire Pt 100, Standard IEC 60 751 Ni 100, Standard DIN 43 760	-200 to +850°C -60 to +250°C	50°C 50°C	850°C 250°C
Thermocouple Type B, E, J, K, N, R, S, T; Standard IEC 60 584-1 Type L and U; Standard DIN 43 710 Type C: W5 Re/W26 Re, Type D: W3 Re/W25 Re; Standard ASTM E 988-90	According to type	2mV ⁽⁵⁾	80mV ⁽⁵⁾

Table 2: Output Response Times

Measuring Mode	Open Sensor Circuit	Short-Circuit	Possible Response Times [s]							
			1.5	2.5	3.5	6.5	11	20.5	40	
TC int. comp.	active	–	1.5	2.5	3.5	6.5	11	20.5	40	
TC int. comp.	off	–	1.5	2.5	3.5	6.5	13.5	24.5	49.5	
TC ext. comp.	active	–	1.5	2.5	3.5	6.5	11	20.5	40	
TC ext. comp.	off	–	1.5	2.5	4	6.5	13.5	24.5	48.5	
RTD 2L	active	–	2	2.5	3	5	9.5	17.5	33.5	
RTD 3L, 4L	active	active	2	2.5	4	6.5	11.5	21	40.5	
RTD 2L, 3L, 4L	off	off	1.5	2.5	3.5	7.5	14	26.5	50.5	

- (4) Submit configuration form shown on page 185, and factory will assign part number prior to order entry.
- (5) Many different ranges may be programmed as long as the min/max limits are observed. For minimum range examples, a K type thermocouple could be programmed for +30°C to +78.5°C, or +100°C to +149°C, or +900°C to 995°C, and so on.

Table 3: Specification and Ordering Information for Factory Configuration

Part Number:	DSCP80-yy-xxxx yy = 01, 02, 03 or 04; xxxx is factory assigned part number	yy = _____ xxxx = _____
Features, Selection		
1. Output variable		
1) Current	end value 20 mA	<input type="checkbox"/>
2) Voltage	end value 10 V	<input type="checkbox"/>
2. Temperature units		
1) Temperatures in °C		<input type="checkbox"/>
2) Temperatures in °F		<input type="checkbox"/>
3) Temperatures in K		<input type="checkbox"/>
3. Measuring mode, input connection		
Thermocouple		
1) Internal cold junction compensation, with built-in or external PT100		<input type="checkbox"/>
2) External cold junction compensation by fixed junction temperature (see NOTE A)	Specify: _____ °	<input type="checkbox"/>
Resistance thermometer		
3) Two-wire connection, R_L (see NOTE B)	Specify: _____ Ω	<input type="checkbox"/>
4) Three-wire connection, $R_L \leq 30\Omega$ /wire		<input type="checkbox"/>
5) Four-wire connection, $R_L \leq 30\Omega$ /wire		<input type="checkbox"/>
NOTE A: Specify external cold junction temperature t_c (in °C, °F or K, acc. to selection in Feature 2), any value between 0 and 60°C or equivalent		
NOTE B: Specify total lead resistance R_L [Ω], any value between 0 and 60Ω		
4. Sensor type/measuring range		
Sensor type/beginning...end value of measuring range*		Specify Range:
1) RTD Pt 100	Specify: _____ Ω (See Note)	_____ ° to _____ °
2) RTD Ni 100	Specify: _____ Ω (See Note)	_____ ° to _____ °
B) TC Type B	_____ ° to _____ °	N) TC Type N _____ ° to _____ °
E) TC Type E	_____ ° to _____ °	R) TC Type R _____ ° to _____ °
J) TC Type J	_____ ° to _____ °	S) TC Type S _____ ° to _____ °
K) TC Type K	_____ ° to _____ °	T) TC Type T _____ ° to _____ °
L) TC Type L	_____ ° to _____ °	U) TC Type U _____ ° to _____ °
C) TC W5-W26RE	_____ ° to _____ °	D) TC W3-W25RE _____ ° to _____ °
NOTE: Specify resistance in Ω at 0°C, any value between 50 and 1000Ω *Specify measuring range in [°C], [°F], or [K]; refer to table 4 for max range operating limits for each type of sensor, table 1 for min/max span limits.		
5. Output characteristic		
0) 20...100% end value	<input type="checkbox"/>	2) Inverted 100...20% end value <input type="checkbox"/>
1) 0...100% end value	<input type="checkbox"/>	3) Inverted 100...0% end value <input type="checkbox"/>
6. Open-circuit sensor detection		
Output response for an open or short-circuit* sensor		
0) Output → at start value + 110% of the span	<input type="checkbox"/>	2) Hold output at last value <input type="checkbox"/>
1) Output (see NOTE)	Specify: _____ %	3) No signal <input type="checkbox"/>
NOTE: Any value between 0 to <110% at dead-zero, resp. -10 to <110% at live-zero *The short-circuit signal is only active for RTD measuring ≥100Ω at 0°C and three or four-wire connection		
7. Output time response		
0) Standard response time approx. 2 seconds	<input type="checkbox"/>	
9) Response time (see Note)		Specify: _____ s
NOTE: For admissible values see Table 2		
8. Mains ripple suppression		
0) Frequency 50 Hz	<input type="checkbox"/>	
1) Frequency 60 Hz	<input type="checkbox"/>	

DSCP

Table 4: Temperature Measuring Ranges

Measuring range examples [°C]	Resistance thermometers		Thermocouples											
	Pt100	Ni100	B	E	J	K	L	N	R	S	T	U	C ⁽¹⁾	D ⁽²⁾
0...40	X			X	X		X							
0...50	X	X		X	X	X	X				X	X		
0...60	X	X		X	X	X	X				X	X		
0...80	X	X		X	X	X	X	X			X	X		
0...100	X	X		X	X	X	X	X			X	X		
0...120	X	X		X	X	X	X	X			X	X		
0...150	X	X		X	X	X	X	X			X	X	X	
0...200	X	X		X	X	X	X	X			X	X	X	X
0...250	X	X		X	X	X	X	X			X	X	X	X
0...300	X			X	X	X	X	X	X	X	X	X	X	X
0...400	X			X	X	X	X	X	X	X	X	X	X	X
0...500	X			X	X	X	X	X	X	X		X	X	X
0...600	X			X	X	X	X	X	X	X		X	X	X
0...800	X		X	X	X	X	X	X	X	X			X	X
0...900			X	X	X	X	X	X	X	X			X	X
0...1000			X	X	X	X		X	X	X			X	X
0...1200			X		X	X		X	X	X			X	X
0...1500			X						X	X			X	X
0...1600			X						X	X			X	X
0...1800			X										X	X
0...2000													X	X
50...150	X	X		X	X	X	X	X			X	X		
100...300	X			X	X	X	X	X			X	X	X	X
200...500	X			X	X	X	X	X	X	X		X	X	X
300...600	X			X	X	X	X	X	X	X		X	X	X
600...900			X	X	X	X	X	X	X	X			X	X
600...1000			X	X	X	X		X	X	X			X	X
900...1200			X		X	X		X	X	X			X	X
600...1600			X						X	X			X	X
600...1800			X										X	X
-10...40	X	X		X	X	X	X					X		
-30...60	X	X		X	X	X	X	X			X	X		
Measuring range limits [°C]	-200 to 850	-60 to 250	0 to 1820	-270 to 1000	-210 to 1200	-270 to 1372	-200 to 900	-270 to 1300	-50 to 1769	-50 to 1769	-270 to 400	-200 to 600	0 to 2315	0 to 2315
	NOTE A		NOTE B											
<p>NOTE A: Minimum span is 15Ω when the end value⁽³⁾ is less than or equal to 400Ω. Minimum span is 150Ω when the end value⁽³⁾ is greater than 400Ω and not exceeding 4000Ω. The ratio of the min value to the span must be less than or equal to 10.</p> <p>NOTE B: Range of span is 2mV minimum to 80mV maximum. The ratio of the min value to the span must be less than or equal to 10.</p> <p>NOTE (1): W5 Re W26 Re (ASTM E 988-90) NOTE (2): W3 Re W25 Re (ASTM E 988-90) NOTE (3): For two-wire connections, the end value is made up of the measured end value (Ω) plus the total resistance of the leads.</p>														

Electrical Connections

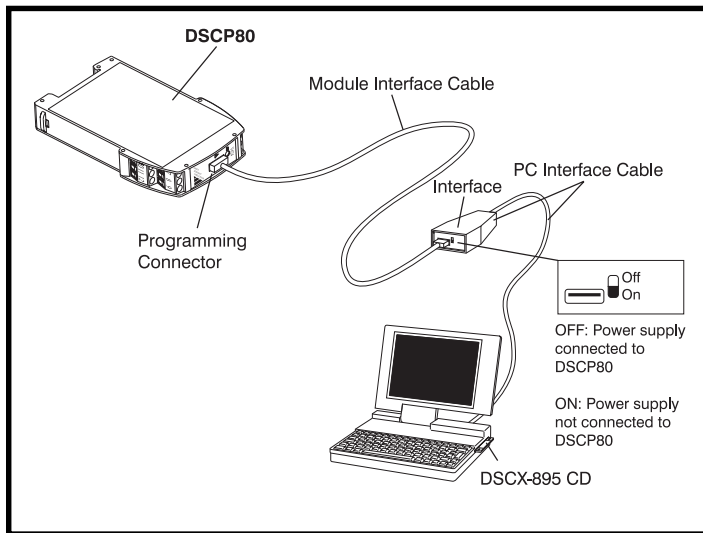
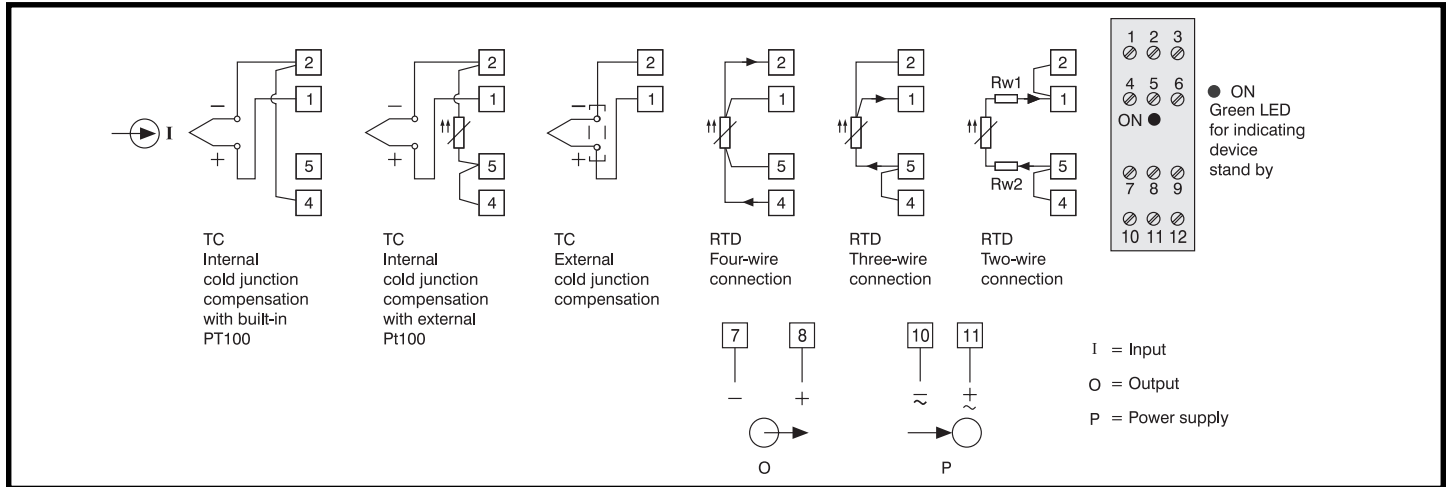

Example of the set-up for programming a DSCP80 without the power supply. For this case the switch on the interface must be set to "ON".

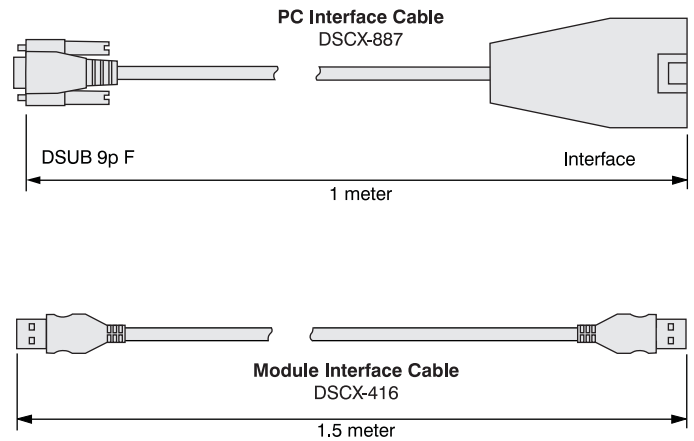

Dimensions

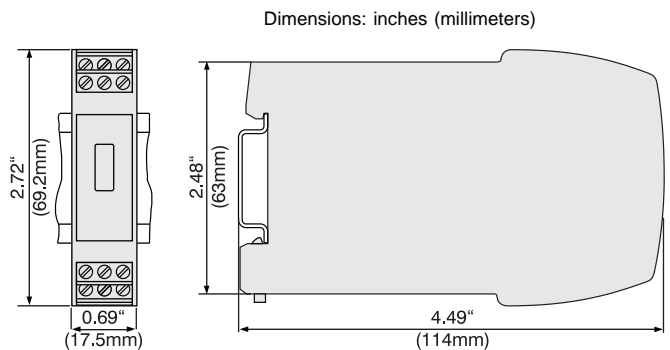

DSCP80 Clipped onto a Top-Hat Rail (35 x 15mm or 35 x 17 mm, acc. to EN 50 022).